

Communication Interface Module Replacement

Removal Procedure

Important: The vehicle communication interface module (VCIM) has a specific set of unique numbers that tie the module to each vehicle. These numbers, the 10-digit station identification and the 11-digit electronic serial number, are used by the National Cellular Network and OnStar® to identify the specific vehicle. Because these numbers are tied to the vehicle identification number of the vehicle, you must never exchange these parts with those of another vehicle.

1. Remove the rear compartment trim. Refer to [Rear Compartment Trim Panel Replacement](#) in Body Rear End.

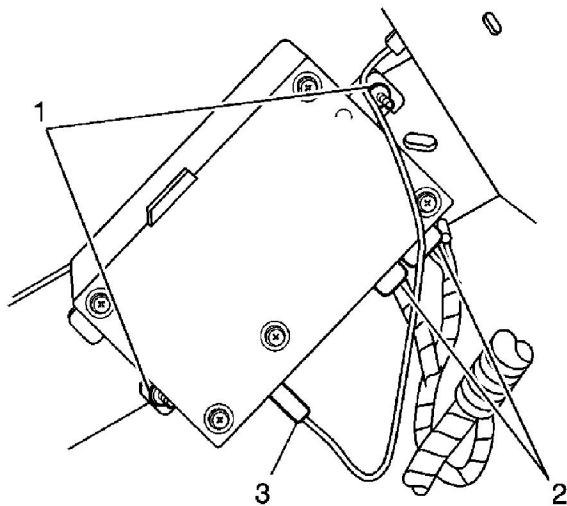

2. Disconnect the antenna (3) and electrical connections (2) from the vehicle communication interface module (VCIM).
3. Remove the bolts (1) securing the VCIM.
4. Remove the vehicle VCIM from the vehicle.

Installation Procedure

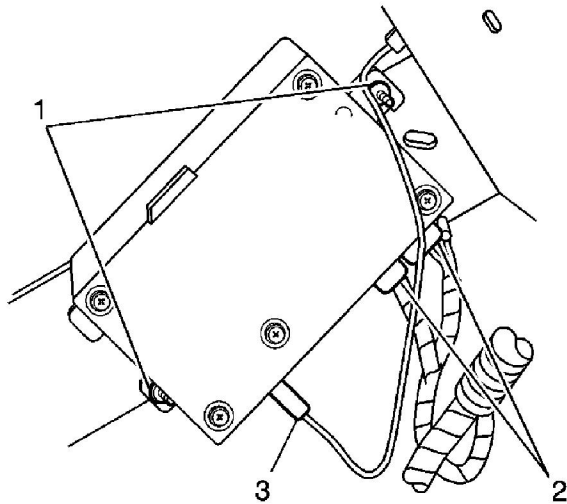

1. When replacing the VCIM, record the 11-digit electronic serial number (ESN) and the 10-digit station identification (STID) number from the label on the new VCIM (4).
2. Position the VCIM in the vehicle.

Notice: Refer to [Fastener Notice](#) in the Preface section.

3. Install the bolts (1).

Tighten

Tighten the bolts (1) to 4 N·m (36 lb in).

4. Connect the antenna cable (2) and electrical connections (3) to the VCIM (4).
5. Install the rear compartment trim. Refer to [Rear Compartment Trim Panel Replacement](#) in Body Rear End.

Important: After replacing the vehicle communication interface module, you must reconfigure the OnStar® system. Failure to reconfigure the system will result in an additional customer visit for repair. In addition, pressing and holding the white dot button on the keypad will NOT reset this version of the OnStar® system. This action will cause a DTC to set.

6. Reconfigure the OnStar® system. Refer to [OnStar Reconfiguration](#) .